

# Flexible Solar Panels

## 100 to 160 Watts

**SARGENT**  
wired for innovation

The SFlex range of solar panels are ideally suited to leisure applications, with their low profile and flexible construction. To aid rapid installation, panel connections are compatible with the Sargent solar regulator range.



Specification	SF100	SF160
Peak Power (Pmax)	100W	160W
Voltage (Vmp)	20.0V	16.5V
Current (Imp)	5.3A	10.6A
O/C Voltage (Voc)	24.0V	19.5V
S/C Current (Isc)	5.60A	10.8A
Cell Efficiency	22.0%	22.0%
Max Flex Angle	20°	20°
Dimensions (mm)	912 x 680	1380 x 680
Weight (Kg)	1.70	2.50
Cable length (metres)	1.5	1.5

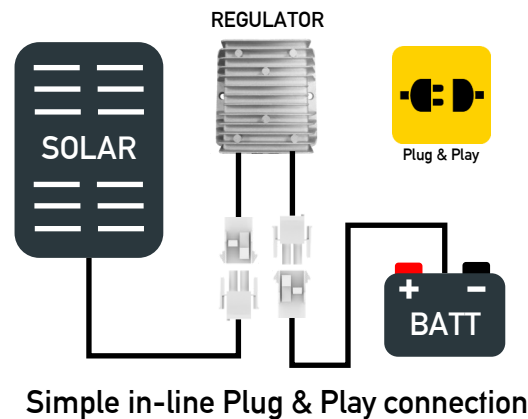
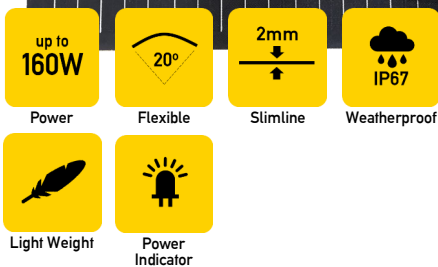

- Output power available from 100 to 160 Watts
- Robust multi-layer construction - with ETFE film coating
- Up to 20 degree flexibility - for mounting onto curved surfaces
- 50-60% weight saving - compared to metal framed panels
- Wafer thin 2mm profile - provides discrete fitment with low drag
- LED power indicator - confirms panel is producing energy
- 10 year output warranty - with 20 year typical life
- IP67 waterproof junction box - with fast-fit connector



Junction Box with LED