

# TL43

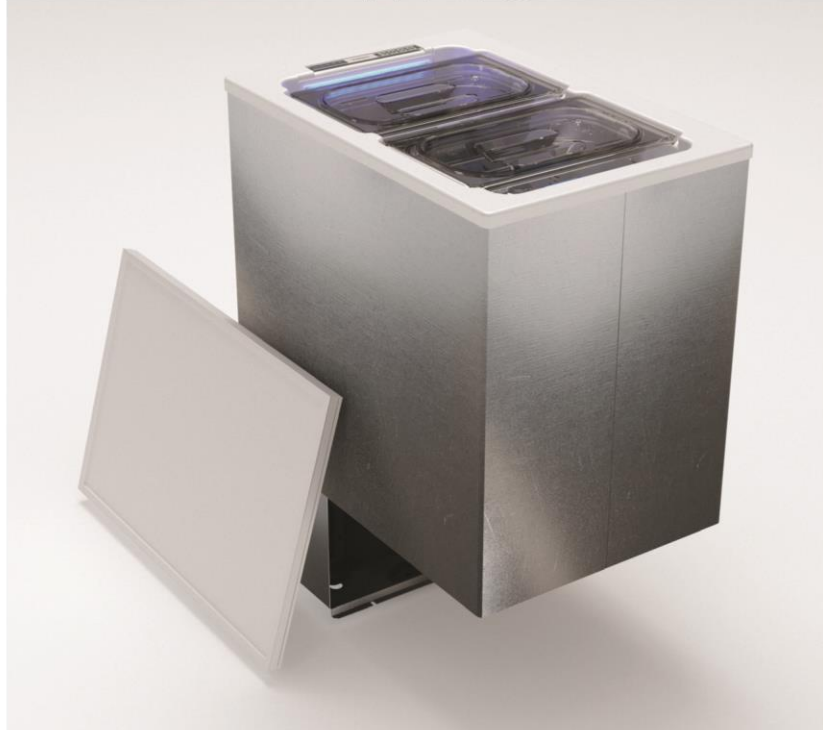

Made in Italy



## 3+ DAYS

RUN FOR  
3 OR MORE DAYS  
ON A 100 A/H  
LEISURE BATTERY

SAVE YOUR MONEY AND THE ENVIRONMENT



Total volume 40 lt.

Net weight 17 kg.

Power supply and  
nominal consumption 12/24 Vdc  
45 W

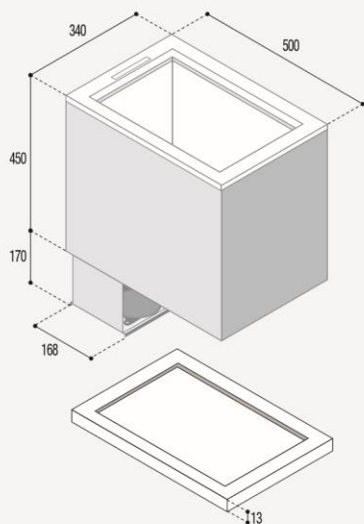

# ► TL43

## COOL FASTER LASTS LONGER



# VITRIFRIGO

COOL AND BEYOND

# ▶ TL43

## TOP LOADING FRIDGE/FREEZER

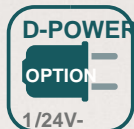

### SPECIALLY DESIGNED FOR VEHICLE INSTALLATION OVER THE WHEEL ARCH

- Using the Vitrifrigo cooling unit for market leading power consumption
- Temperature control with Innovative Membrane LED Digital Thermostat featuring:
  - Turbo mode for fast chill to achieve temperature quicker

- Night mode for minimum noise level and reduced power consumption when running at night
- Inside out fixings and concealed lid fixings for easy installation
- Internal LED light
- Removable seal
- Optional external drain
- Smart storage for large and small bottles with FDA approved food storage containers
- Option to remote mount the compressor up to 1.5mt

### SMART STORAGE

